



# ATV BACKPACKER

*Save your breath for braggin!*



**Caution:**

For Safety Read and  
Follow Assembly and  
Operating Instructions  
Carefully

## ASSEMBLY INSTRUCTIONS & OWNER'S MANUAL

**McCONKEY INC.**  
P.O. Box 1362  
Seeley Lake, MT 59868

**NEED HELP?** Please visit us at [www.atvbackpackercart.com](http://www.atvbackpackercart.com)

## Safety

Like any piece of equipment, the ATV Backpacker cart can cause injury if operated improperly, or if the user does not understand how to operate the equipment. **Use caution at all times when using your towing vehicle and cart:**

- Read this owner's manual and follow all warnings and cautions on page 3 before attempting to assemble or operate this cart.
- Read your tow vehicle's owner's manual and know how to operate your tow vehicle before towing cart.
- Never allow children or inexperienced adults to operate the tow vehicle or cart.
- Recommended tow vehicle engine size is 350 cc or larger, with four-wheel drive, in order to allow safe operation when towing the cart.
- Towing heavy loads with the cart may affect your tow vehicle's braking and stability. Do not exceed your tow vehicle's towing capacity. Check the vehicle's owner's manual on tow capacity limitations before using cart.
- Use caution when towing the cart over rough, steep or uneven terrain to prevent rolling over and loss of control. Be careful towing the cart when conditions are icy, wet or snowy, as these types of driving conditions could impair the towing and braking ability of your towing vehicle.
- Use extreme caution when towing the cart on steep slopes. This cart is not equipped with brakes and may decrease your tow vehicle's braking ability and stability.
- Do not tow this cart on highways or on public thoroughfares or behind larger vehicles, such as pickup trucks or cars. This cart is designed for off road use only.
- Before folding the cart and stowing it on the back of your tow vehicle read your tow vehicle's owner's manual and never exceed your rear rack load or tailgate capacity.
- Never operate your tow vehicle when the cart is folded up and stowed behind your vehicle without first securing the cart to your tow vehicle with the proper size ropes, straps, etc.
- Never operate your tow vehicle on steep, slippery or uneven terrain when the cart is folded up and stowed behind your vehicle. These types of conditions may affect your vehicle's stability.
- This cart is not designed or equipped to transport people.

### LIMITED WARRANTY

*McConkey INC. warrants the ATV Backpacker to be new and free from material defect for six (6) months from the date of delivery of the ATV Backpacker to Buyer. This limited warranty will be satisfied by McConkey INC.'s repairing the ATV Backpacker or furnishing a replacement or parts, at its option. For this warranty to be effective, Buyer must immediately, and within the warranty period, notify its seller of the claimed defect. McConkey INC. shall have no obligation under this warranty for an ATV Backpacker which has been repaired or altered, or defects which result from misuse, improper assembly of the ATV Backpacker, or improper connection of the ATV Backpacker to a tow vehicle. THIS IS THE BUYER'S EXCLUSIVE REMEDY UNDER WARRANTY. MCCONKEY INC. DISCLAIMS ALL OTHER WARRANTIES, EXPRESSED OR IMPLIED, INCLUDING BUT NOT LIMITED TO WARRANTIES OF MERCHANTABILITY, FITNESS FOR A PARTICULAR PURPOSE, AND AGAINST INFRINGEMENT. THIS WARRANTY IS NOT TRANSFERABLE.*

 **WARNING**

Do not operate your tow vehicle on steep or uneven terrain while the cart is upright, folded and attached to the back of the tow vehicle. Operating a vehicle while the cart is in this position can result in loss of control and cause death or serious injury.

- Do not exceed your tow vehicle's rear rack or tailgate load limit.
- Do not transport the cart and tow vehicle in a pickup truck or trailer until the cart is secured to the tow vehicle with proper sized fasteners, ropes, straps, etc.

 **WARNING**

Do not operate this cart on public roads. This cart is intended for off-road use only. Driving on public roads and/or too fast for conditions can result in loss of control and cause death or serious injury.

- Do not exceed 20 mph while towing or carrying this cart.
- Decrease your speed as weather and lighting conditions deteriorate.

 **WARNING**

An improperly coupled cart can result in death or serious injury. Do not tow the cart until:

- The coupler is secure and locked to hitch, using an 1-7/8 inch ball;
- Tires, wheels, pins, nuts and bolts are checked; and
- The load is secured to the cart.

 **WARNING**

Improper tire pressure can result in a blowout and loss of control, which can lead to death or serious injury.

- Be sure tires are inflated to pressure indicated on sidewall before towing cart.

 **WARNING**

Nuts, bolts and pins are prone to loosen after initial installation, and if improperly checked and/or tightened, can lead to death or serious injury.

- Check, tighten and secure all nuts, bolts and pins before each use.

 **WARNING**

An overloaded cart or improper distribution of load weight or shifting cargo can result in loss of control of the cart, leading to death or serious injury.

- Do not exceed the cart's Gross Vehicle Weight Rating (800 lbs. GVWR)
- Do not exceed the cart's tongue weight rating of (350 lbs.)
- Do not exceed your tow vehicle's towing and tongue weight capacities.
- Tie down all loads with proper-sized fasteners, ropes, straps, etc.

Be sure to:

- Distribute the load front-to-rear and provide proper tongue weight;
- Distribute the load evenly, right and left, to avoid tire overload; and
- Keep the center of gravity low.

 **CAUTION**

Hinged joints and unions associated with the carts mechanics can create pinch points, which could cause injury.











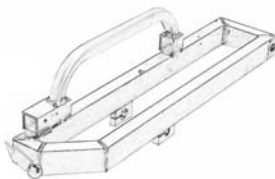

# ATV BACKPACKER

*Save your breath for braggin!*

**Congratulations and Thank You** for purchasing the strongest and most convenient pull-behind ATV cart on the market today. You will now be able to fully unlock your ATV's potential and make it a truly useful machine.

Please follow the enclosed assembly instructions closely. For your convenience, we have pre-assembled and packaged as many components as possible.

## HARDWARE & PARTS CHECKLIST

 <p>Cart Frame</p>		 <p>(2) Wheel Frames</p>		 <p>(2) Wheels</p>	
 <p>Rear Axle Shaft</p>		 <p>Hitch &amp; Tongue</p>		 <p>(2) Lever Arms</p>	
		 <p>(2) Wheel Axles</p>		 <p>(4) Wheel Axle Brackets</p>	
 <p>Tongue Nut &amp; Bolt</p>		 <p>Tongue Pin &amp; Key</p>		 <p>(8) Wheel Axle Bolts</p>	
		 <p>(2) Rear Axle Nuts</p>		 <p>(4) Wheel Spacers</p>	
				 <p>(2) Level Arm Pins &amp; Keys</p>	

## CART ASSEMBLY

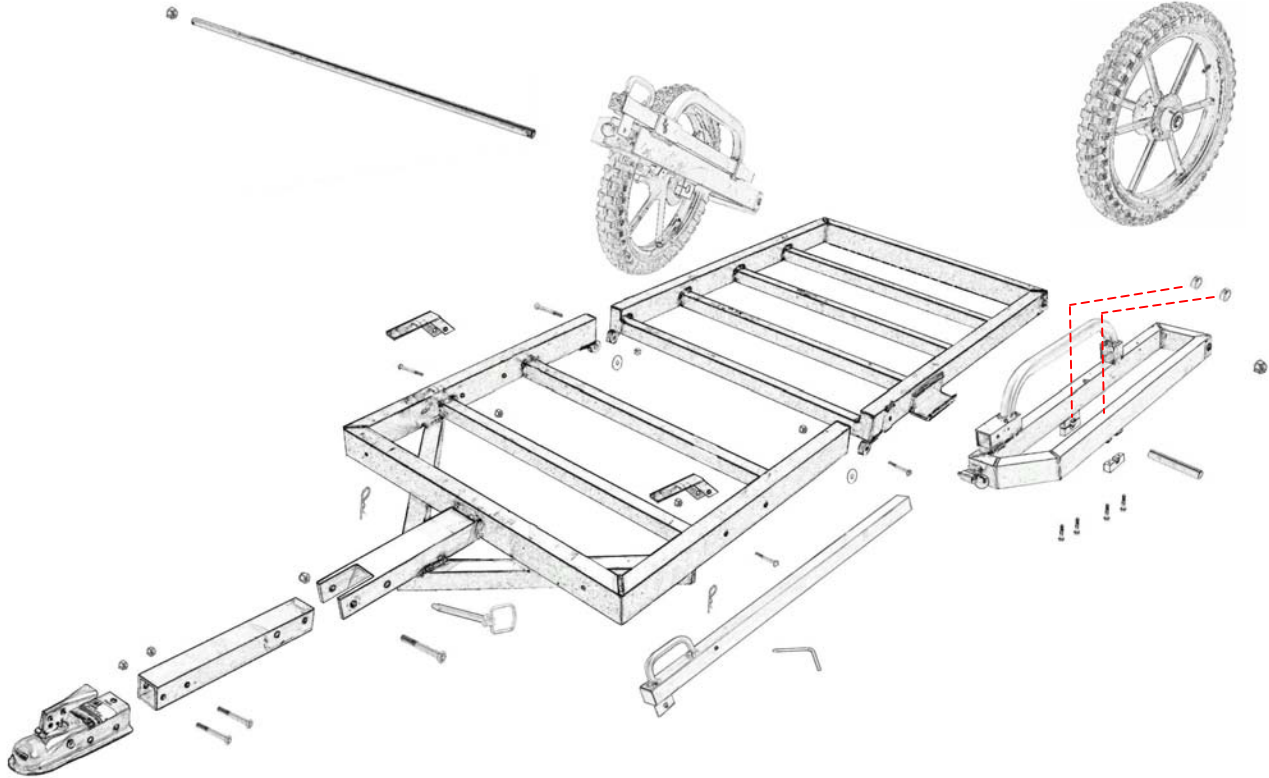

1. Attach the tongue to the frame by using the tongue bolt and nut. (*Note; over tightening this union will not allow the cart to fold properly, and may damage the tongue.*)
2. Assemble the wheel to the wheel frame by sliding the wheel axle through the wheel. Then slide the wheel spacers over the axle on the inside and outside of the wheel. Next, place the wheel and axle inside the wheel frame, resting the axle on the wheel frame brackets. Make sure that the wheel spacers are inside the wheel frame and that the axle is flush with the inside and outside of the wheel frame. Place the wheel axle brackets over the inside and outside of the axle on the bottom of the wheel frame and tighten bolts. (*Do not over tighten.*)
3. Assemble the wheel frames to the cart by sliding the rear axle shaft through the left wheel frame; continue sliding the axle through the rear of the cart frame and through the right side wheel frame. Next, thread on the large rear axle nuts and tighten. (*Note; make sure the nuts are snug, but do not over-tighten, over-tightening this union will not allow the cart to work properly.*)
4. The hanger brackets have come pre-assembled to the cart frame. However, the hanger brackets may be moved depending on the type of vehicle you are using to stow the cart on. The hanger bracket holes closest to the front of the cart are for smaller ATVs. The next sets behind them are for larger UTVs. (*Note; the hanger brackets must be placed in the correct set of holes for the towing vehicle, or the cart will not stow properly and could result in equipment damage or personal injury. See Figure 3, page 6*)

# OPERATING INSTRUCTIONS

Check tire pressure and check, tighten and secure all nuts, bolts and pins before each use. Also, remember to read and follow all warnings on pages 2 & 3.

## FOLDING CART AND ATTACHING CART TO REAR OF THE VEHICLE



Figure 1.

When folding the cart, first engage the parking brake on the vehicle and hitch the cart to the 1-7/8 inch ball on the back of the vehicle. Second, remove the lever arm pins and slide the lever back in place along the wheel (Figure 1). Next, remove the larger tongue pin behind the hitch (Figure 2).

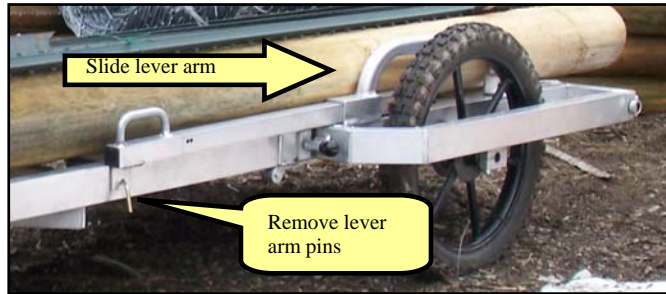

Figure 2.

After removing the pins, raise the hanger brackets so that they are open and ready to hook on to the back of your vehicle (Figure 3). Then, walk to the rear of the cart and raise the back of the frame to your waist and place in lap. Next, grasp the wheel guards and lift up while walking toward the rear of the vehicle. Now, raise the front of the cart frame and hook the hanger brackets on the rear of the vehicle. Secure the cart to the vehicle with fasteners, (ropes, straps, etc.) when transporting the cart and vehicle in a pickup truck or trailer, additional fasteners, (ropes, straps, etc.) will be needed to secure the cart to the vehicle.



Figure 3.

**\*IMPORTANT:** Make sure the hanger brackets are in the correct set of holes for the towing vehicle you are using to stow the cart on. (See step 4 on page 5 and Figure 3)

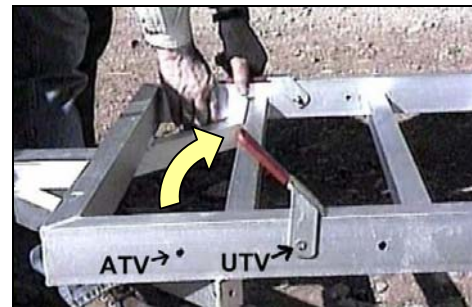

To see a demonstrational video of the ATV BACKPACKER cart in action, visit us at [www.atvbackpackercart.com](http://www.atvbackpackercart.com).

## LIFTING HEAVY LOADS WITH CART



Depending on the cargo, this feature may be used with the cart either attached or detached from the ATV.

Figure 4.

With the cart deployed, first unlock the wheels by removing the lever pins and pulling out on the spring-loaded catch pin on each side. This will allow your cart to lay flat on the ground. Then, rotate the wheels to the back of the cart (Figure 4). Next, roll your cargo onto the center of the cart. *(If you are loading your cargo on a side slope, it may be to your advantage to leave the down hill wheel pinned in place, which will allow the cart to remain level when loading your cargo.)*



Figure 5.

To lift the cargo with the cart, extend the lever arm and pull out on the spring-loaded catch pin while pushing down and in on the lever arm (Figure 5). This process lifts the bed of the cart. Once the spring-loaded pin is locked in place, keep the lever arm extended and insert the lever pin in place, as shown in Figure 1. Repeat this action on the opposite side. Then secure your load to the cart with the proper fasteners, rope, straps, etc.

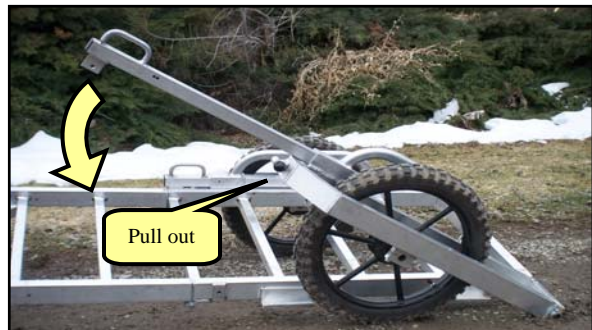

**\*IMPORTANT:** Do not overload the front of the cart. The bulk of the weight should be positioned over the wheels. Too much weight placed on the front of the cart may damage the tongue.